

TYPE: EPT-DT80/100/120 4VT
**Three Phase (4 MOV/GDT in Series Modules)
Surge Protection Devices**

Surge arrester for low-voltage power supply system protection against surges at the boundaries from lightning protection zone 0_B-1 and higher.

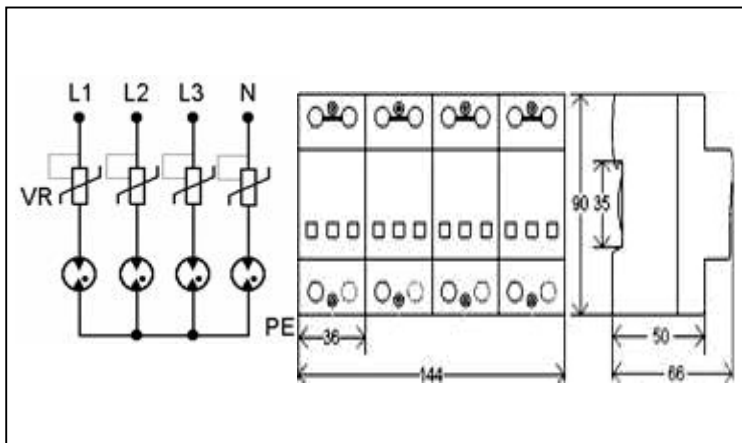

- Class II (C) arrester in according with IEC61643-1:2001.
- Two part design consisting of base and non-pluggable protection module.
- High energy MOV (Metal Oxide Varistor) hybrid unit inside.
- Reliable supervision due to disconnection device.
- Fault indication by red indication flag in window.
- Fast response.
- With remote alarm terminal optional.

Technical Data

Type	EPT- DT80/xxx-4VT-S									
	150	175	275	300	320	385	440	550	600	
In accordance with	IEC61643-1:2001; EN61643-1 2002; UL1449 ed.2									
Category IEC/VDE	II/ C									
Max. continuous operating voltage (AC/DC)	150 /200	175 /225	275 /300	300 /385	320 /420	385 /505	440 /585	550 /745	600 /800	
Nominal discharge current(8/20) In	L-N	40KA	40KA	40KA	40KA	40KA	40KA	40KA	40KA	40KA
	N-PE	40KA	40KA	40KA	40KA	40KA	40KA	40KA	40KA	40KA
Max. discharge current(8/20) Imax	L-N	80/100/120KA								
	N - PE	80KA								
Voltage protection level	@In	0.6KV	0.6KV	1.2KV	1.2KV	1.2KV	1.2KV	1.8KV	2.4KV	2.4KV
	@3KA	0.5KV	0.5KV	0.8KV	0.8KV	0.8KV	0.8KV	1.2KV	1.6KV	1.6KV
Response time	L-N	≤ 100 ns								
	N-PE	≤ 100 ns								
Follow current	L-N	No								
	N-PE	No								
Residual current at Uc	L-N	No								
	N-PE	No								
Backup fuse(only required if not already provided in mains)	200A gL/gG									
Operating temperature range	- 40° C ... + 80° C									
Cross-section of connection wire	Single-strand 35mm ² ; multi-strand 25mm ²									
Mounting	35mm DIN-rail in accordance with EN 50022/DIN46277-3									
Enclosure material	thermoplastic; extinguishing degree UL94 V-0									
Degree of protection	IP20									
Installation width	8 modules, DIN 43880									
Thermal disconnecter	Internal green – normal red - failure									
Remote alarm contact	Optional									